

	Product Specification	Version
		V1.0
Product Type	Infrared Laser Fixed Focus Lens	
Product Name	IR-850-1W-D30	
Product Number	R10030004	
Product Size	D*H=Φ12*9.2mm	
Application Range: Safe city, large-scale factory, intelligent transportation, on-board system, airport port, oil depot, security department, prison, water conservancy and electric power, energy mining, ecological protection, administrative law enforcement, fishery and sea surveillance, border defense and other night vision monitoring fill light.		
Statement: This specification is copyrighted by 3KM Optoelectronics Technology Co., Ltd. and may not be distributed to employees who are 3KM away without the written approval of the 3KM. It may not be used, copied or modified in whole or in part, and may not be disclosed in any way. 3KM reserve the right to update the technical parameters of the product to ensure that the latest and best products are provided to the customer.		
3KM Optoelectronics Technology Co., Ltd.		File Type: Specification
Prepared	LGN	Sep 29, 2019
Review	LZHJ	Sep30, 2019
Approve	WYM	Sep30, 2019

Parameters	
Item	Parameters
Size	D*H: 12mm*9.2mm
Applicable Wavelength Range	800nm~980nm
Illumination Angle	30°(@ 1/e ²)
Material	Polycarb
Applicable LightSource	IR-850-1W-3838 (3KM VCSEL)
Storage Temperature	-50°C~+100°C
Operating Temperature	-40°C~+85°C
Environmental Standards	(EU)2015/863

Product Size

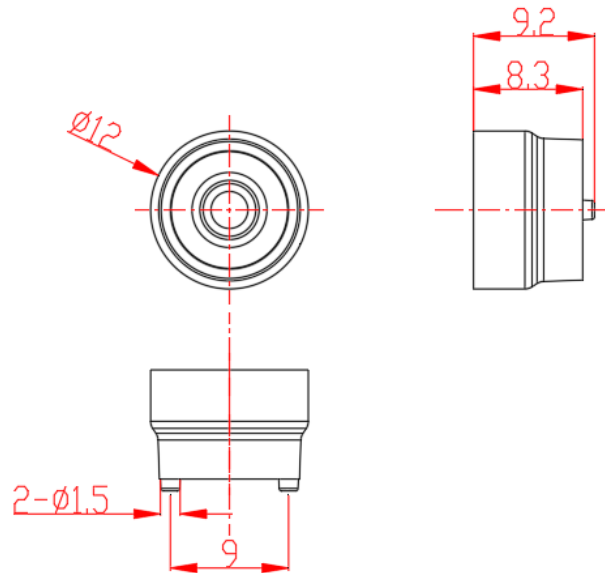

unit: mm

Optical Angle

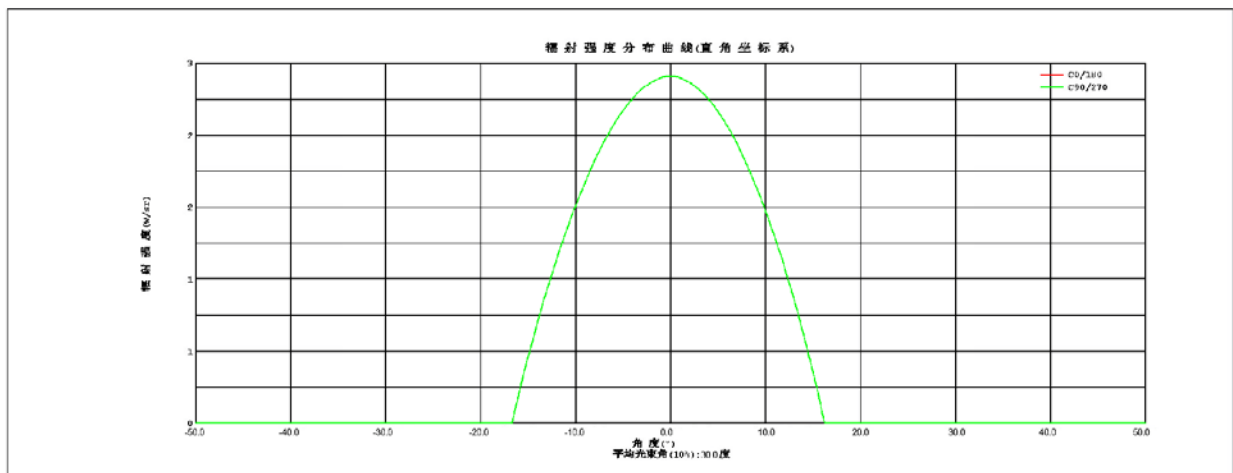

Contact Information

Company Name:	3KM Optoelectronics Technology Co., Ltd.
Business Phone:	+86-0755-6686 4401
Company website:	www.sz3km.cn
Email:	sales@sz3km.com
Address:	12F, Building 1, Heng Changrong Hi-Tech Park, No. 128 Shangnan East Road, Xinqiao Street, Baoan District, Shenzhen, P.R.C